

ECLIPSE SERVO and AC MOTOR BRAKES
Spring Engaged, Air Released, with Clamping Collar

Servo Motors: Sizes 2,3,4,5;

IEC, AC Motors: Sizes 71, 80, 90



NEMA Motors: Sizes 56 C, 143 TC, 145 TC



In accordance with Nexen's established policy of constant product improvement, the specifications contained in this manual are subject to change without notice. Technical data listed in this manual are based on the latest information available at the time of printing and are also subject to change without notice.

Technical Support: 800-843-7445
(651) 484-5900

www.nexengroup.com

	<p style="text-align: center;"> DANGER</p> <p>Read this manual carefully before installation and operation. Follow Nexen's instructions and integrate this unit into your system with care. This unit should be installed, operated and maintained by qualified personnel ONLY. Improper installation can damage your system, cause injury or death. Comply with all applicable codes.</p>	
---	---	---

This document is the original, non-translated, version.

Conformity Declaration: In accordance with Appendix II B of CE Machinery Directive (2006/42/EC):

A Declaration of Incorporation of Partly Completed Machinery evaluation for the applicable EU directives was carried out for this product in accordance with the Machinery Directive. The declaration of incorporation is set out in writing in a separate document and can be requested if required.

This machinery is incomplete and must not be put into service until the machinery into which it is to be incorporated has been declared in conformity with the applicable provisions of the Directive.

Nexen Group, Inc.
560 Oak Grove Parkway
Vadnais Heights, Minnesota 55127

ISO 9001 Certified

Copyright 2014 Nexen Group, Inc.

Table of Contents

General Specifications	4
General Safety Precautions	4
Installation:	
Mounted on the Shaft End of a Motor	5
Mounted between a Gear Reducer and a Motor	6
Lubrication	7
Air Connections	8
Operation	9
Brake Assembly	10
Troubleshooting	11
Replacement Parts List	12
Accessories	13
Warranty	14

GENERAL SPECIFICATIONS

Size	Min Holding Torque	Torsional Rigidity (Estimated)	Inertia (Calculated)	Weight	Min. Disengagement Air Pressure
Size 2	2.25 Nm [1.66 ft*lb]	6180 Nm/RAD [4550 ft*lb/RAD]	0.00002 kg*m ² [0.0005 lb*ft ²]	1.1 kg [2.4 lbs]	5.5 bar [80 psi]
Size 3	8 Nm [5.90 ft*lb]	9613 Nm/RAD [7090 ft*lb/RAD]	0.00005 kg*m ² [0.0012 lb*ft ²]	1.5 kg [3.2 lbs]	5.5 bar [80 psi]
Size 4	22 Nm [16.2 ft*lb]	23,796 Nm/RAD [17,550 ft*lb/RAD]	0.00031 kg*m ² [0.0074 lb*ft ²]	3 kg [8.5 lbs]	5.5 bar [80 psi]
Size 5	45 Nm [33 ft*lb]	36,184 Nm/RAD [26,690 ft*lb/RAD]	0.00114 kg*m ² [0.0271 lb*ft ²]	6.3 kg [13.8 lbs]	5.5 bar [80 psi]
IEC 71	14 Nm [10.3 ft*lb]	8120 Nm/RAD [5990 ft*lb/RAD]	0.00031 kg*m ² [0.0074 lb*ft ²]	10 kg [22 lbs]	3.3 bar [48 psi]
IEC 80	45 Nm [33 ft*lb]	13,450 Nm/RAD [9,920 ft*lb/RAD]	0.0014 kg*m ² [0.033 lb*ft ²]	15 kg [33 lbs]	5.5 bar [80 psi]
IEC 90	45 Nm [33 ft*lb]	29,560 Nm/RAD [21,800 ft*lb/RAD]	0.0014 kg*m ² [0.033 lb*ft ²]	15 kg [33 lbs]	5.5 bar [80 psi]
EMB 625	45 Nm [33 ft*lb]	5,430 Nm/RAD [4000 ft*lb/RAD]	0.0014 kg*m ² [0.033 lb*ft ²]	12.5 kg [27 lbs]	5.5 bar [80 psi]
EMB 875	45 Nm [33 ft*lb]	20,470 Nm/RAD [15,100 ft*lb/RAD]	0.0014 kg*m ² [0.033 lb*ft ²]	12.5 kg [27 lbs]	5.5 bar [80 psi]

Pneumatic units accept an optional solenoid valve (normally closed) controlled by 24VDC at 104 mA. Solenoid valves are fitted with 18" flying leads standard. To order the solenoid valve (optional), please refer to Nexen product #964650.

GENERAL SAFETY PRECAUTIONS



CAUTION
Some product assemblies can exceed 30 lbs. Use lifting aids and proper lifting techniques when installing, removing, or placing in service.



CAUTION
The output shaft needs to be enclosed either by gear reducer or appropriate guarding. Failure to guard could result in serious bodily injury.



CAUTION
Watch for sharp features when interacting with this product. The parts have complex shapes and machined edges.



WARNING
This product is capable of emitting a spark if misused, therefore it is not recommended for use in any explosive environment.

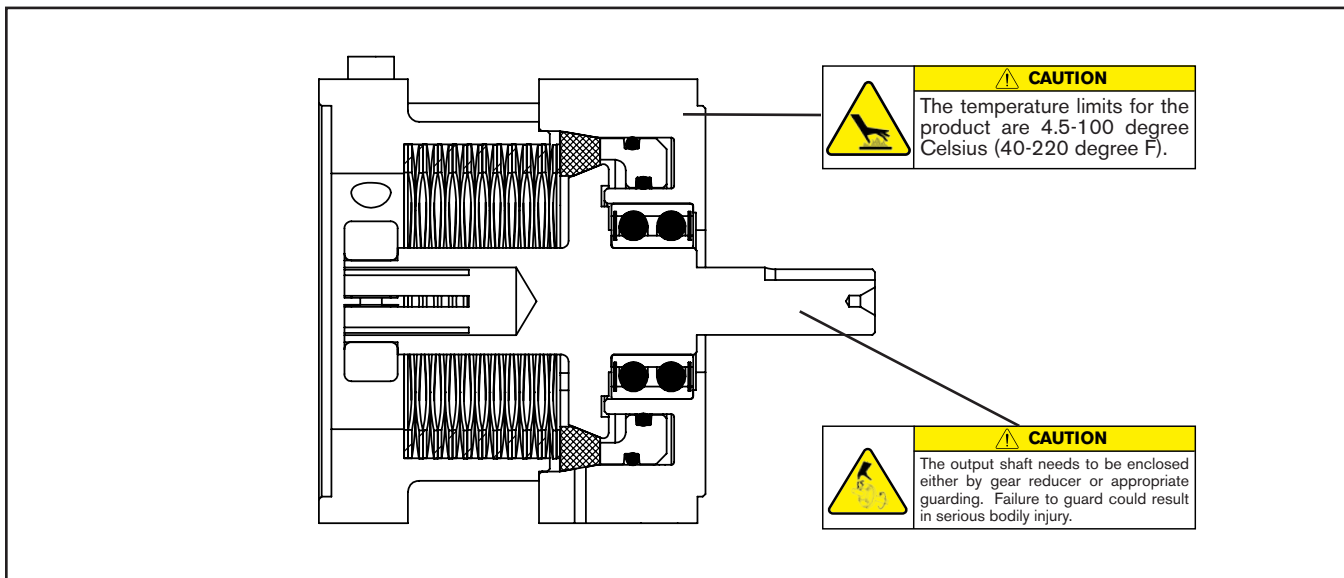

INSTALLATION

MOUNTED ON THE SHAFT END OF A MOTOR

NOTE: Refer to Figures 1, 2 & 3.

1. Place the Clamping Collar (Item 7) on the input (female) end of the brake shaft. Finger tighten the cap screw until the Collar is nearly snug. Then slide the Collar down the Shaft until it is firmly against the shaft step.

NOTE: Some Clamp Collars require two cap screws to provide necessary clamp load.

2. Remove the Access Plugs (Item 14) from the Input Flange (Item 10). Rotate the Clamping Collar (Item 7) until the cap screw is lined up with the access hole. Then insert an Allen driver or a T-handle wrench through and engage the head of the cap screw. Leave this driver or wrench in place while you perform the next two steps.

CAUTION: Do not lubricate either the Clamping Collar or the Shaft. Any lubricant on the contact surfaces could result in torque transfer failure. If necessary, clean the Shaft with a non-petroleum based solvent, such as isopropyl alcohol, and wipe dry before assembly.

3. Slide the Motor Shaft into the input (female) end of the Output Shaft (Item 1) until the Flanges of the Motor and Brake come together.
4. Using four customer-supplied Socket Head Cap Screws (See Table 2), bolt the Flanges together. Tighten the cap screws evenly to the recommended torques listed in Table 2 (Page 6).
5. Using the Allen driver or wrench used in Step 2, tighten the cap screws in the Clamping Collar (Item 7) to the recommended torque listed in Table 1 (Page 6).

CAUTION: Under tightening the Collar may cause slippage between the motor and the Brake. This can cause damage to the System, Motor and/or Brake.

6. Reinstall the Access Plugs (Item 14) into the access holes on the Input Flange (Item 10).
7. Attach the Gear Reducer or the load to the Brake Shaft.

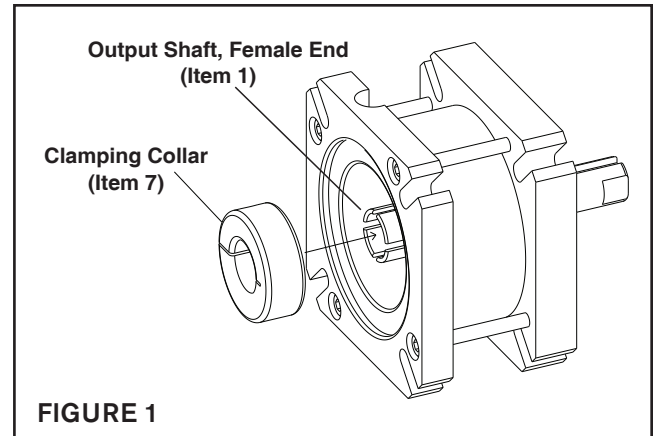

FIGURE 1

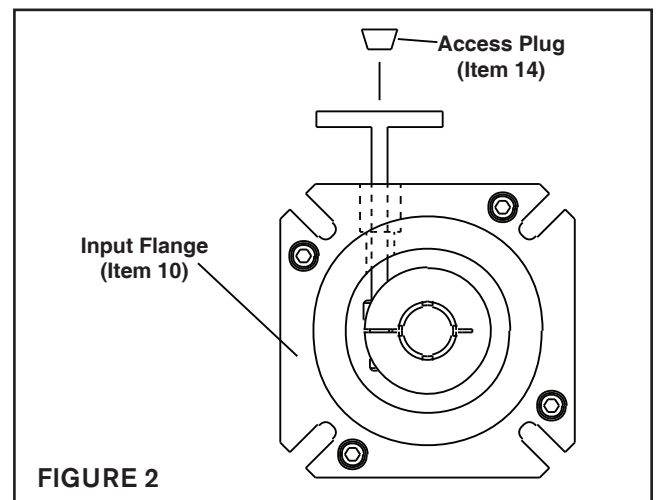

FIGURE 2

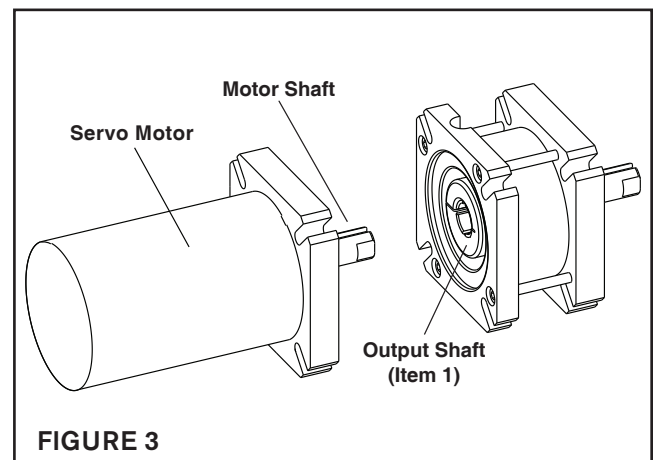



FIGURE 3

	⚠ DANGER
	Support the load before disengaging the brake. Failure to support the load could result in serious bodily injury.

INSTALLATION

MOUNTED BETWEEN A GEAR REDUCER AND A MOTOR

NOTE: Refer to Figure 4.

1. To mount the brake to the Motor, follow steps 1-11 on pages 5-6.
2. Insert the Brake Shaft into the customer supplied gear reducer coupling. Use the supplied Key (Item 20) (if required).
3. Use customer supplied screws, washers and nuts to bolt the flanges together. Apply Loctite® 242 the threads of the screws. For recommended torque values, refer to Table 2.
4. Tighten the Coupling. Refer to the instructions that are supplied with the Gear Reducer.
5. Install any plugs or related items that are detailed in the Gear Reducer instructions.

TABLE 1

Brake Model	Cap Screw	Recommended Collar Screw Torque
Size 2	M5	9.5 Nm [84.1 in-lb]
Size 3	M6	16 Nm [142.0 in-lb]
Size 4	M6	16 Nm [142.0 in-lb]
Size 5	M6	16 Nm [142.0 in-lb]
EMB 110-14 EMB 130-19 EMB 130-24	M6	16 Nm [142.0 in-lb]
EMB 625 EMB 875	M6	16 Nm [142.0 in-lb]

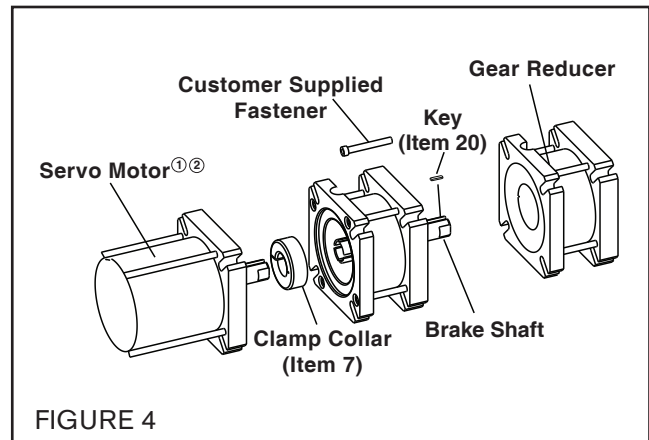

① Models EMB 110-14, EMB 130-19 and EMB 130-24 have round flanges and fit IEC Frame, B5, AC Motors.

② Models EMB 625 and 875 have round flanges and fit NEMA Frame, AC Motors.

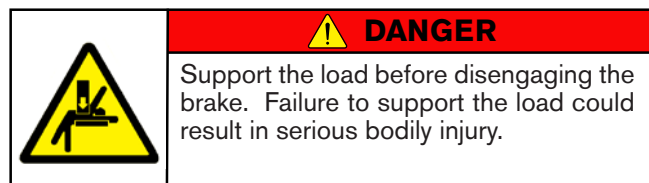

TABLE 2

Brake Model	Socket Head Cap Screw (Customer Supplied)	Recommended Fastening Torque
Size 2	M5	7 Nm [63 in-lb]
Size 3	M6	12 Nm [107 in-lb]
Size 4	M8	29 Nm [260 in-lb]
Size 5	M10	58 Nm [520 in-lb]
EMB 110-14 EMB 130-19 EMB 130-24	M10	58 Nm [520 in-lb]
EMB 625 EMB 875	M10	58 Nm [520 in-lb]

LUBRICATION

NOTE

Nexen pneumatically actuated devices require clean, pressure regulated air for maximum performance and life. All seals in Nexen pneumatically operated devices are lubricated for life, and do not require additional lubrication.

However, some customers prefer to use an air line lubricator, which injects oil into the pressurized air, forcing an oil mist into the air chamber. This is acceptable, but care must be taken to ensure once an air mist lubrication system is used, it is continually used over the life of the product as the oil mist may wash free the factory installed lubrication.

Locate the lubricator above and within ten feet of the product, and use low viscosity oil such as SAE-10.

Synthetic lubricants are not recommended.

Nexen product's bearings are shielded and pre-lubricated, and require no further lubrication.

	CAUTION
	<p>These settings are for Nexen supplied lubricators. If you are not using a Nexen lubricator, calibration must follow the manufacturer's suggested procedure.</p>

LUBRICATOR DRIP RATE SETTINGS

1. Close and disconnect the air line from the unit.
2. Turn the Lubricator Adjustment Knob counterclockwise three complete turns.
3. Open the air line.

4. Close the air line to the unit when a drop of oil forms in the Lubricator Sight Gage.
5. Connect the air line to the unit.
6. Turn the Lubricator Adjustment Knob clockwise until closed.
7. Turn the Lubricator Adjustment Knob counterclockwise one-third turn.
8. Open the air line to the unit.

AIR CONNECTIONS

All Nexen pneumatically actuated devices require clean and dry air, which meet or exceeds ISO 8573.1:2001 Class 4.4.3 quality.

NOTE

For quick response, Nexen recommends a quick exhaust valve and short air lines between the Control Valves and the unit. Align the air inlet ports to a down position to allow condensation to drain out of the air chambers of the product.

	CAUTION
	<p>Low air pressure will cause slippage and overheating. Excessive air pressure will cause abrupt starts and stops, reducing product life.</p>

The following is a common air supply scheme used with this product. This is an example and not an all-inclusive list. All air circuits to be used with this product must be designed following ISO 4414 guidelines.

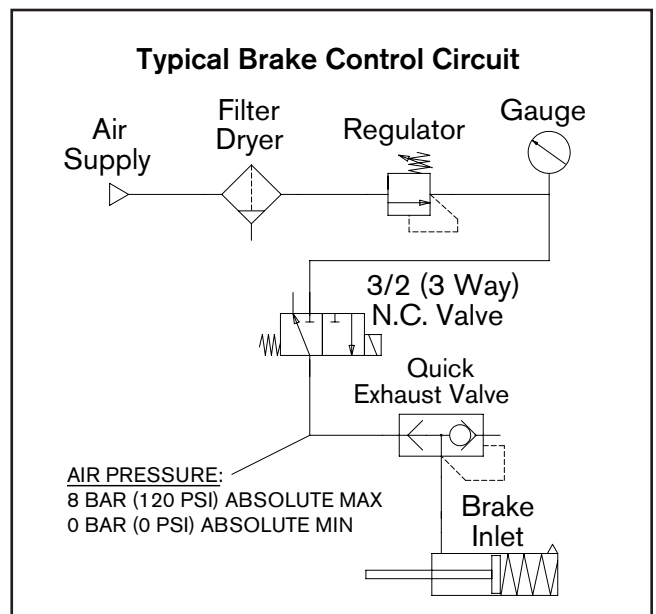

AIR CONNECTIONS *(continued)*

DANGER

Support the load before disengaging the brake. Failure to support the load could result in serious bodily injury.

1. Standard Configuration:

Attach the Quick Exhaust Valve (Item 23) to the brake. Use Teflon tape and/or pipe sealant on the threads.

With Optional Solenoid:

If you are using the optional Solenoid Valve (Nexen Part #964650), the Quick Exhaust Valve is unnecessary. Assemble the optional Solenoid Valve directly to the brake using the supplied fittings. Use Teflon tape and/or pipe sealant on the threads. Refer to Figure 5.

CAUTION

The brake will disengage if you depress the domed button at the top of the Solenoid Valve (if air pressure is applied). The LED will illuminate when the Solenoid Valve is actuated and the brake is disengaged. Pressure needed to disengage should NOT exceed 80 psi.

NOTE: Align the air inlet ports in the down position to allow condensation to drain out of the air chamber.

2. Assemble the air line to the valve.
3. If using optional solenoid valve, attach DIN Connector cable to valve by pressing DIN Connector onto valve power pins and tightening DIN Connector fastener. Then connect DIN Connector cable wires, using the following chart, to the appropriate power supply, see Table 3.

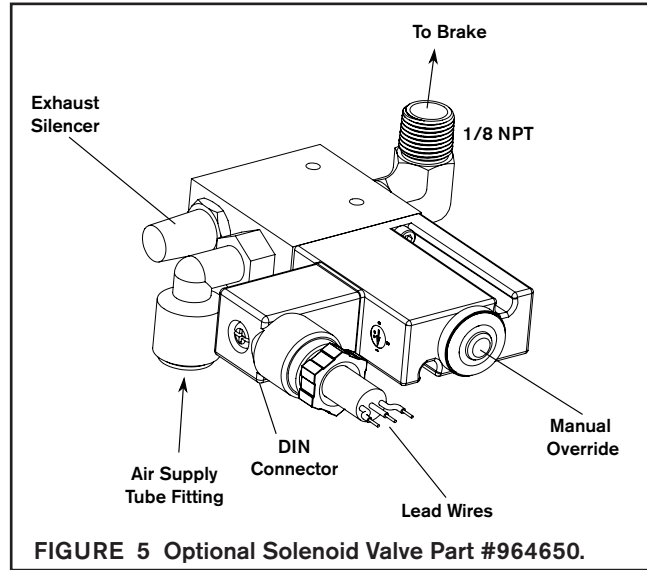

FIGURE 5 Optional Solenoid Valve Part #964650.

DIN Connector Cable Wire Color	Valve	
	24 VDC	Valve Pin
Brown	+	1
White	-	2
Green	Ground	Ground

CAUTION

24 VDC valve connector has a suppression diode installed across the coil. Observe proper voltage polarity or connector damage will result.

Table 3

Optional Solenoid Valve Specifications				
Voltage	Power	Resistance	Current	Cv
24 VDC	4 W	145 ohms	.17 A	.25

OPERATION



	WARNING
Never exceed maximum operating speeds listed for your product. (See Table 4).	

TABLE 4

Sizes	Max RPM
Size 2, 3, 4, 5	10,000
IEC 71, 80, 90	10,000
EMB 625, 875	5,000

	CAUTION
Never exceed life of facing material. Facing life depends on the volume of material and the total energy over the life of the unit. Expected life (in hrs) can be found by: $\text{Time} = \text{Volume} / (\text{Power} * \text{Wear Rate})$.	

	CAUTION
The temperature limits for this product line are 4.5-100 Degree Celsius (40-220 Degree F).	

BRAKE ASSEMBLY

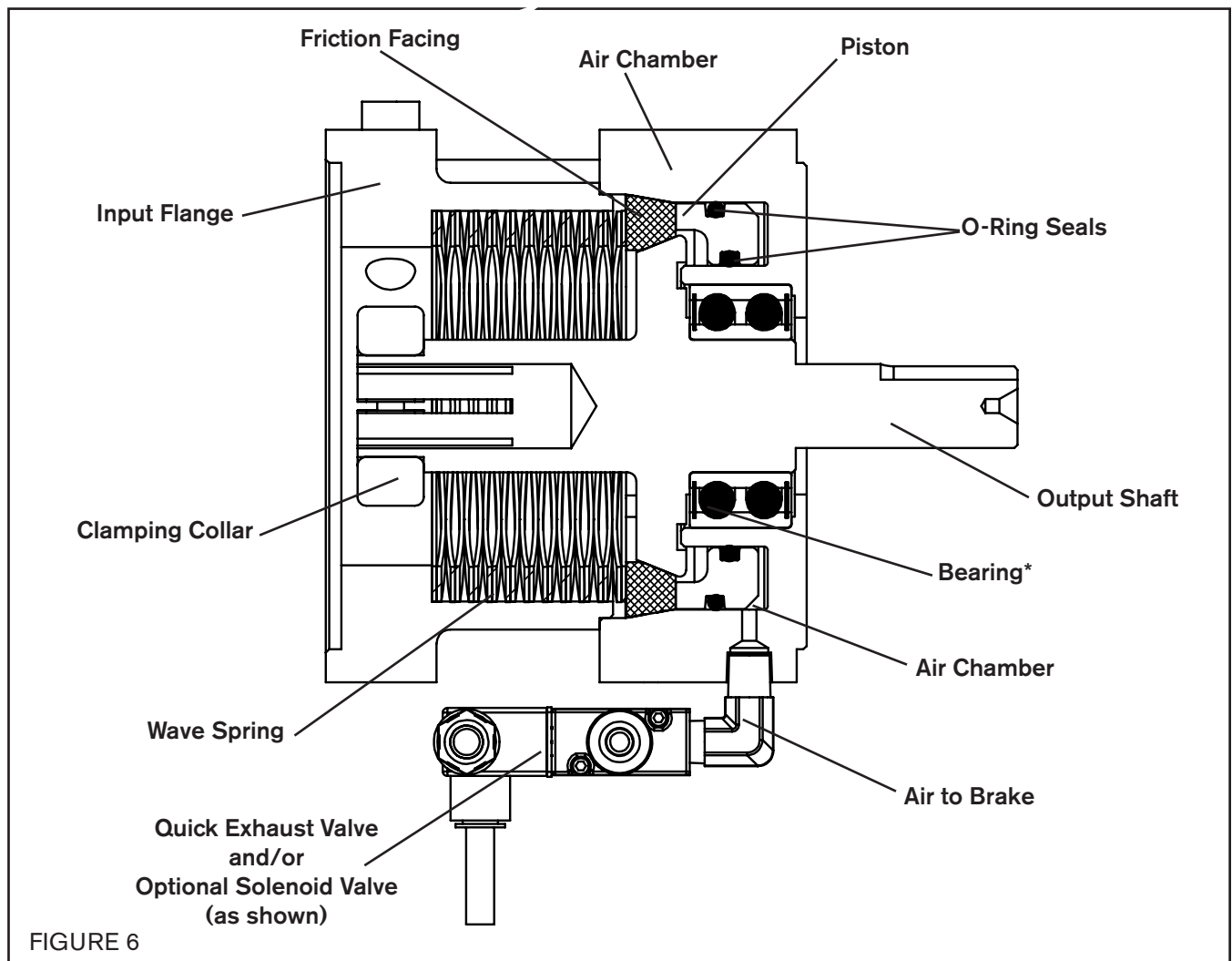

*Note: This is a single row bearing in EMB 625, EMB 875, and Servo Size 5.

BRAKE ASSEMBLY

SIZES 2, 3, 4, 5; EMB 110-14, EMB 130-19, EMB 130-24, EMB 625 & EMB 875

NOTE: Refer to Figures 7 & 8.

1. Alternately and evenly, remove the four Socket Head Cap Screws (Item 11) and separate the Air Chamber (Item 6) from the Input Flange (Item 10).
2. Remove the Output Shaft (Item 1) from the Ball Bearing (Item 2) by pressing in on the output shaft. Remove the Dowel Pin (Item 21) by pressing the Dowel Pin into the Air Chamber.
3. Remove the Piston (Item 5) from the Air Chamber (Item 6). You may need to apply compressed air to the air inlet to remove the Piston.
4. Remove the old O-ring Seals (Items 3, 4) from the Piston.
5. Press the Bearing (Item 2) out of the Air Chamber (Item 6).
6. Clean the bearing bore of the Air Chamber (Item 6) with fresh solvent, removing old Loctite®.
7. Apply a continuous bead of Loctite® 680 around the inner circumference of the Air Chamber (Item 6) bearing bore.
8. Carefully align the outer race of the new Bearing (Item 2) with the bore of the Air Chamber (Item 6).
9. Supporting the Air Chamber (Item 6) and pressing on the outer race of the new Bearing (Item 2), press the new Bearing into the Air Chamber.
10. Visually inspect the inner diameter grooves and the outer diameter grooves of the Piston (Item 5) for debris. Clean as necessary.
11. Coat the O-ring contact surfaces of the Air Chamber (Item 6), the Piston (Item 5), and the O-ring Seals (Items 3, 4) with a thin film of O-ring lubricant and install the new O-ring Seals.
12. Slide the Piston (Item 5) into the Air Chamber (Item 6).

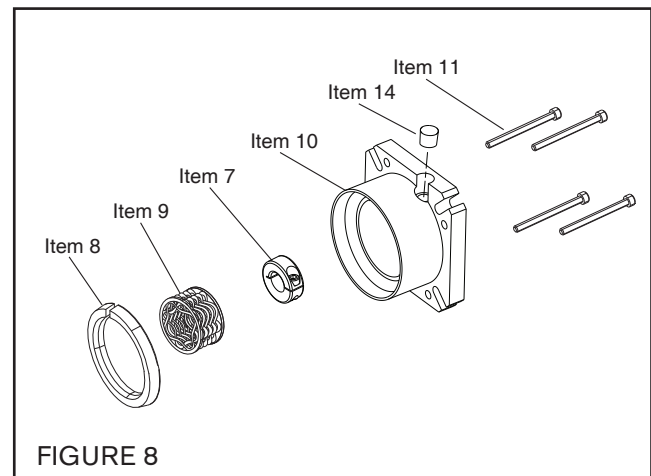
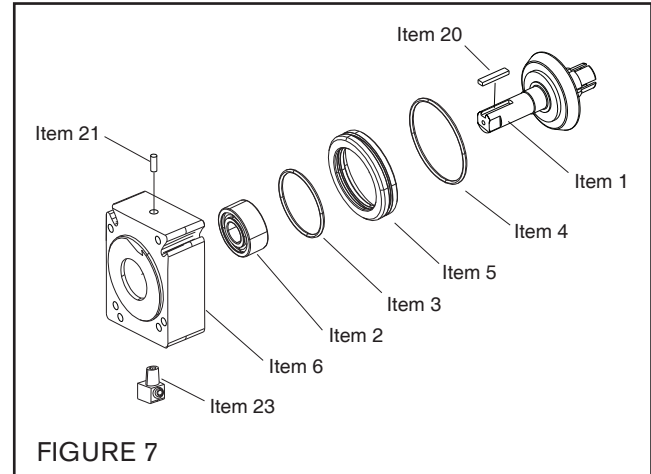
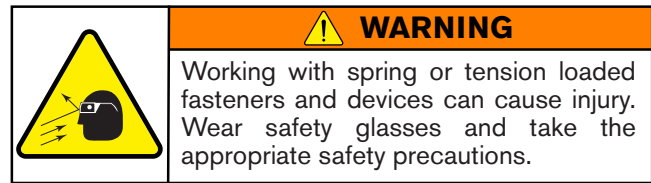

(continued)

BRAKE ASSEMBLY *(continued)*

13. Clean the friction surface of the Air Chamber (Item 6) and Output Shaft (Item 1) with solvent.
14. Reinstall Dowel Pin (Item 21) by pressing into Air Chamber (Item 6) until flush with the outside surface.
15. Position Friction Facing on top of the piston with the narrow end of the taper pointing down and the anti-rotation facing slot aligned with the Dowel Pin (Item 21). Use care to ensure that the Friction Facing is concentric to the piston, as this will aid in the installation of the output shaft in step 16.
16. Support the inner race of the new Ball Bearing (Item 2) and press the Output Shaft (Item 1) into the new Bearing (Item 2) and Air Chamber (Item 6).
17. Replace the Wave Spring (Item 9) and Input Flange (Item 10).

NOTE: On the Size 2 Spring, one end will be fused. Be sure that the fused end is down and makes contact with the facing (Item 8).

18. Apply a drop of Loctite® 242 to the threads of the Socket Head Cap Screws (Item 11).
19. Reinstall and tighten the four Socket Head Cap Screws (Item 11), securing the Air Chamber (Item 6) to the Input Flange (Item 10). Alternate as you tighten the four Socket Head Cap Screws so that the Input Flange remains evenly parallel to the Air Chamber. Refer to Table 5 for the recommended assembly torque values.

TABLE 5

Brake Model	Socket Head Cap Screw (Item 11)	Recommended Assembly Torque
Size 2	M4	4.2-5.4 Nm [37-48 in-lb]
Size 3	M5	7.0-9.2 Nm [62-81 in-lb]
Size 4 EMB 110-14	M6	9.2-11.9 Nm [81-105 in-lb]
Size 5	M8	26.2-34.0 Nm [232-301 in-lb]
EMB 130-19 EMB 130-24	M8	26.2-34.0 Nm [232-301 in-lb]
EMB 625 EMB 875	M8	26.2-34.0 Nm [232-301 in-lb]

TROUBLESHOOTING

Problem	Probable Cause	Solution
Failure to engage (brake).	Weak or broken spring.	Replace broken spring.
Failure to disengage (1).	Control valve malfunction - air not getting to the brake.	Check for low air pressure or replace the control valve. Note: Pressure needed to disengage is shown in the specifications table, page 4.
Failure to disengage (2).	Air is leaking around the O-ring seals.	Replace the O-rings.
Loss of torque.	Friction Facing is worn or dirty.	Replace the Friction Facing.

REPLACEMENT PARTS LIST

The item or balloon number for all Nexen products is used for part identification on all product parts lists, product price lists, unit assembly drawings, bills of materials, and instruction manuals.

When ordering replacement parts, specify model designation, item number, part description, and quantity. Purchase replacement parts through your local Nexen Distributor.

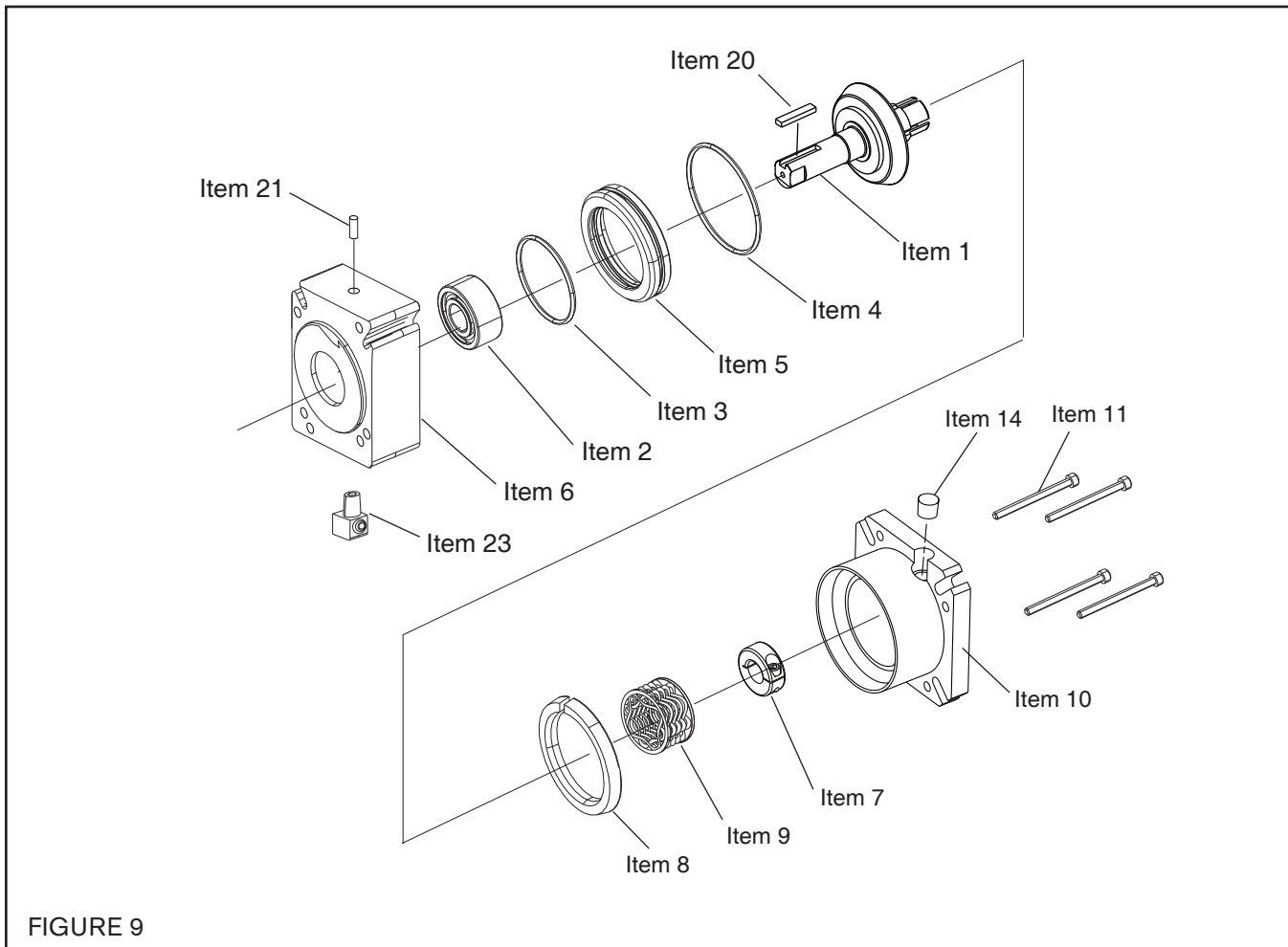

FIGURE 9

NOTE: Items #6 and #10 are round on models EMB 110-14, EMB 130-19, EMB 130-24, EMB 625 and EMB 875.

ITEM	DESCRIPTION	QTY
1	Output Shaft	1
2 ¹	Ball Bearing	1
3 ¹	O-ring Seal	1
4 ¹	O-ring Seal	1
5	Piston	1
6	Air Chamber	1
7	Clamping Collar	1
8 ¹	Friction Facing	1
9 ¹	Wave Spring	1
10	Input Flange	1
11	Socket Head Cap Screw	4
12	Solenoid Valve (Optional)	1
14	Access Plug	1
20	Square Key	1
21	Dowel Pin	1
23	Quick Exhaust Valve, Eclipse	1

¹ Typical parts needed to restore the unit to new condition. Order parts by item number for specific product numbers and model sizes.

ACCESSORIES

DESCRIPTION	PROD. NO.
Optional Solenoid Valve-----	964650

WARRANTY

Warranties

Nexen warrants that the Products will (a) be free from any defects in material or workmanship for a period of 12 months from the date of shipment, and (b) will meet and perform in accordance with the specifications in any engineering drawing specifically for the Product that is in Nexen's current product catalogue, or that is accessible at the Nexen website, or that is attached to this Quotation and that specifically refers to this Quotation by its number, subject in all cases to any limitations and exclusions set out in the drawing. NEXEN MAKES NO OTHER WARRANTY, EXPRESS OR IMPLIED, AND ALL IMPLIED WARRANTIES, INCLUDING WITHOUT LIMITATION, IMPLIED WARRANTIES OF MERCHANTABILITY AND FITNESS FOR A PARTICULAR PURPOSE ARE HEREBY DISCLAIMED. This warranty applies only if: (a) the Product has been installed, used and maintained in accordance with any applicable Nexen installation or maintenance manual for the Product; (b) the alleged defect is not attributable to normal wear and tear; (c) the Product has not been altered, misused or used for purposes other than those for which it was intended; and (d) Buyer has given written notice of the alleged defect to Nexen, and delivered the allegedly defective Product to Nexen, within one year of the date of shipment.

Exclusive Remedy

The exclusive remedy for the Buyer for any breach of any warranties provided in connection with this agreement will be, at the election of Nexen: (a) repair or replacement with new, serviceably used, or reconditioned parts or products; or (b) issuance of credit in the amount of the purchase price paid to Nexen by the Buyer for the Products.

Agent's Authority

Buyer agrees that no agent, employee or representative of Nexen has authority to bind Nexen to any affirmation, representation, or warranty concerning the Products other than those warranties expressly set forth herein.

Limitation on Nexen's Liability

TO THE EXTENT PERMITTED BY LAW NEXEN SHALL HAVE NO LIABILITY TO BUYER OR ANY OTHER PERSON FOR INCIDENTAL DAMAGES, SPECIAL DAMAGES, CONSEQUENTIAL DAMAGES OR OTHER DAMAGES OF ANY KIND OR NATURE WHATSOEVER, WHETHER ARISING OUT OF BREACH OF WARRANTY OR OTHER BREACH OF CONTRACT, NEGLIGENCE OR OTHER TORT, OR OTHERWISE, EVEN IF NEXEN SHALL HAVE BEEN ADVISED OF THE POSSIBILITY OR LIKELIHOOD OF SUCH POTENTIAL LOSS OR DAMAGE. For all of the purposes hereof, the term "consequential damages" shall include lost profits, penalties, delay damages, liquidated damages or other damages and liabilities which Buyer shall be obligated to pay or which Buyer may incur based upon, related to or arising out of its contracts with its customers or other third parties. In no event shall Nexen be liable for any amount of damages in excess of amounts paid by Buyer for Products or services as to which a breach of contract has been determined to exist. The parties expressly agree that the price for the Products and the services was determined in consideration of the limitation on damages set forth herein and such limitation has been specifically bargained for and constitutes an agreed allocation of risk which shall survive the determination of any court of competent jurisdiction that any remedy herein fails of its essential purpose.

Inspection

Buyer shall inspect all shipments of Products upon arrival and shall notify Nexen in writing, of any shortages or other failures to conform to these terms and conditions which are reasonably discoverable upon arrival without opening any carton or box in which the Products are contained. Such notice shall be sent within 14 days following arrival. All notifications shall be accompanied by packing slips, inspection reports and other documents necessary to support Buyer's claims. In addition to the foregoing obligations, in the event that Buyer receives Products that Buyer did not order, Buyer shall return the erroneously shipped Products to Nexen within thirty (30) days of the date of the invoice for such Products; Nexen will pay reasonable freight charges for the timely return of the erroneously shipped Products, and issue a credit to Buyer for the returned Products at the price Buyer paid for them, including any shipping expenses that Nexen charged Buyer. All shortages, overages and nonconformities not reported to Nexen as required by this section will be deemed waived.

Limitation on Actions

No action, regardless of form, arising out of any transaction to which these terms and conditions are applicable may be brought by the Buyer more than one year after the cause of action has accrued.

nexen[®]

Nexen Group, Inc.
560 Oak Grove Parkway
Vadnais Heights, MN 55127

800.843.7445
Fax: 651.286.1099
www.nexengroup.com

ISO 9001 Certified